

AWM Stack Kit 40

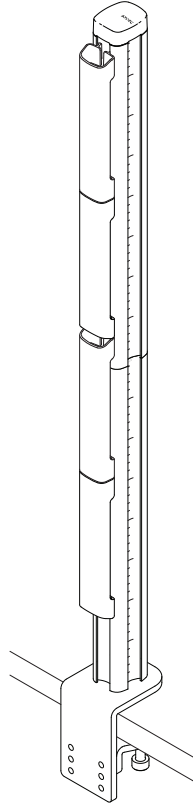

COMPONENT CHECKLIST



A
M6 Threaded Rod
with M8 Tips
(x2)

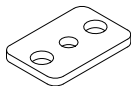

B
M6 Washer
Plate
(x1)



C
M6 Split
Washer
(x2)



D
M6 Nut
(x2)

Desk 

REQUIRED TOOLS

- 10mm (3/8") Wrench
- 8mm (5/16") Wrench (unstacking only)

IMPORTANT INFORMATION

- ! Please ensure this product is installed as per these installation instructions.
- ! This product is **only** compatible with Atdec AWM Post 40 Stackable (AWM-P40X).
- ! Both posts must be AWM-P40X when using this kit.
- ! The manufacturer accepts no responsibility for incorrect installation.

IMPORTANT Check Desk Fixing (fixing sold separately)



When stacking posts only the following heavy duty fixings can be used:

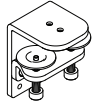

AWM-FH

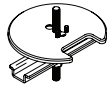

AC-GC

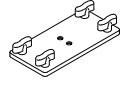

Atdec Custom Rail Plate



1.1 If lower post is already installed, the fixing on the lower post may need to be changed. Follow the installation guide provided with your heavy duty fixing to attach it to the post and fit it to the worksurface.

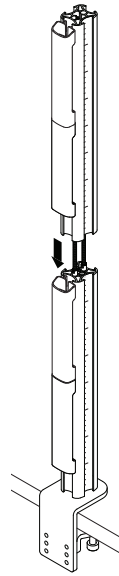

NOTE:

Posts can be stacked before or after attaching to desk fixing.

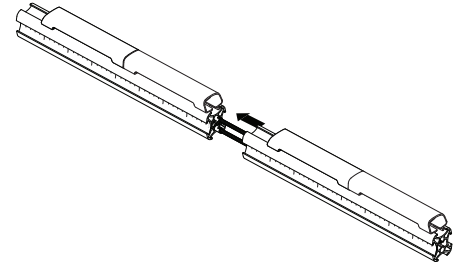

STACKING INSTRUCTIONS

1. Screw Threaded Rods into Post

1.1 Remove post cap and label on both posts.

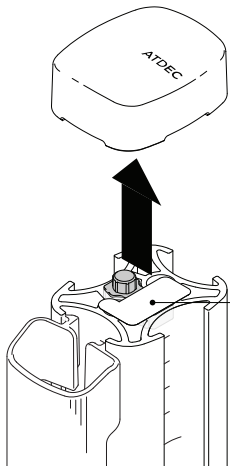

remove label but ensure alignment insert stays in place.

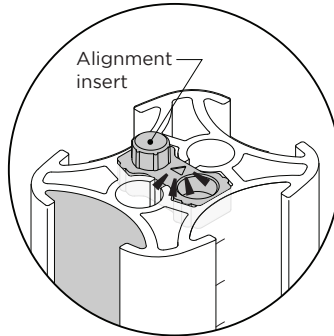

If alignment insert falls out, reposition it as shown above. Ensure arrow on alignment insert points away from the post channel without guide marks on both posts.

1.2 Screw threaded rods into the end of one post that has the alignment insert.

NOTE

Rods can be finger tightened

Alignment insert

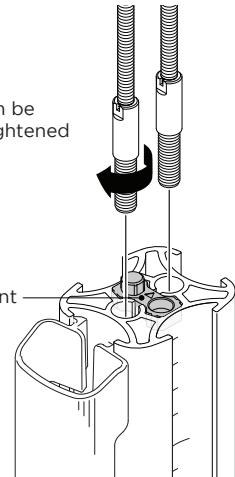

2. Stack Post

2.1 Align the second post with its alignment insert facing the tips of the rods. Then feed the threaded rod into the holes of the second post.

Ensure channels without guide marks are aligned on both posts.

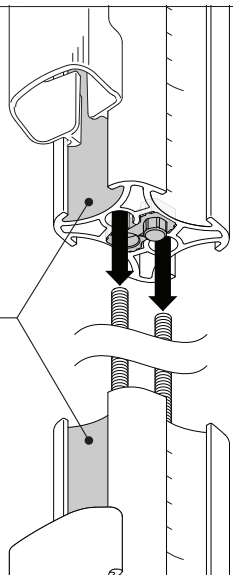

2.2 Slide the post down the rods until it sits flush against the top of the lower post.

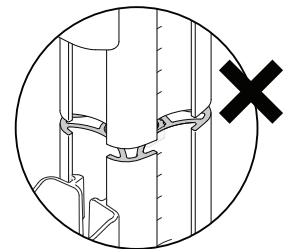
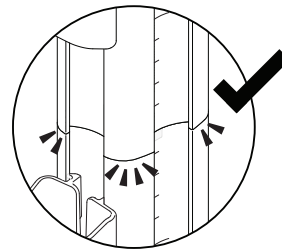

3. Fasten Posts Together

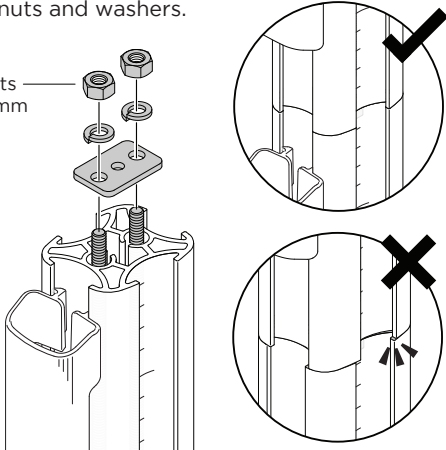
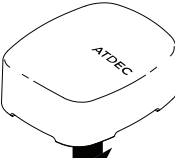
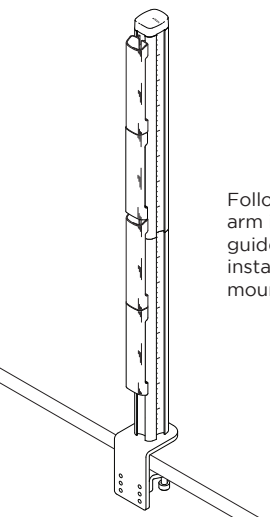
<p>3.1 Screw together the posts using the provided nuts and washers.</p> <p>Tighten two nuts firmly using 10mm (3/8") wrench.</p>  <p>Ensure the post join area remains well aligned while tightening the nuts.</p>	<p>3.2 Fit post cap</p> 	<p>Installation Complete</p> <p>Follow post and arm installation guides to complete installation of your mounting solution.</p> 
-------------------------------------------------------------------------------------------------------------------------------------------------------------------------------------------------------------------------------------------------------------------------------------------------------------	------------------------------------------------------------------------------------------------------------------	----------------------------------------------------------------------------------------------------------------------------------------------------------------------------------------------------------------------------

UNSTACKING INSTRUCTIONS

1. Remove Stacked Post

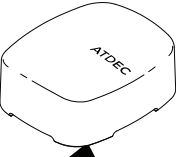
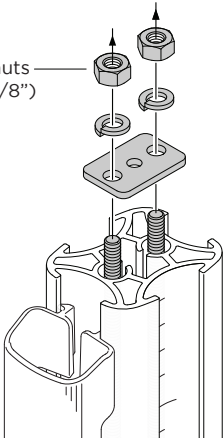
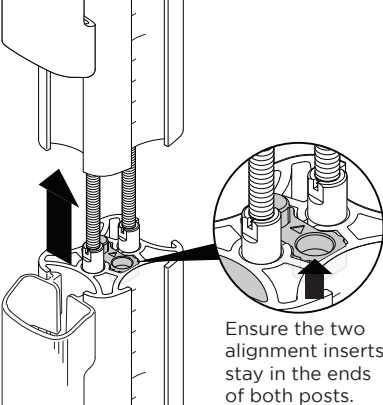
<p>1.1 Remove cap and all monitor arms from the stacked post.</p> 	<p>1.2 Remove nuts and washers from top of post.</p> <p>Unscrew two nuts using 10mm (3/8") wrench.</p> 	<p>1.3 Slide stacked post up off the threaded rods.</p> <p>Ensure the two alignment inserts stay in the ends of both posts.</p> 
-------------------------------------------------------------------------------------------------------------------------------------------------------------	--------------------------------------------------------------------------------------------------------------------------------------------------------------------------------------------------	-----------------------------------------------------------------------------------------------------------------------------------------------------------------------------------------------------------------------------

2. Remove Threaded rods

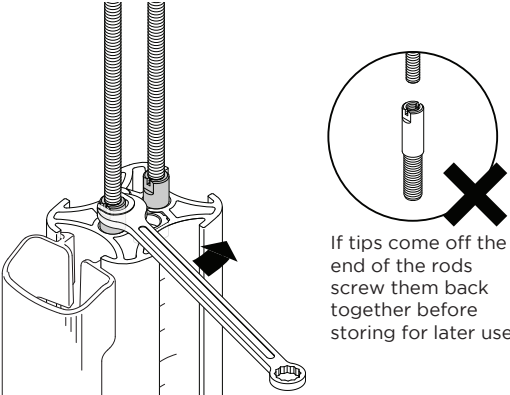
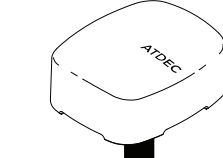
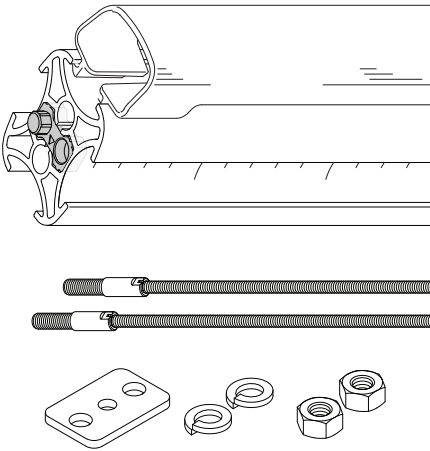
<p>2.1 Unscrew two threaded rods using an 8mm (5/16") wrench.</p> <p>If tips come off the end of the rods screw them back together before storing for later use.</p> 	<p>2.2 Fit post cap</p> 	<p>2.3 Store parts together for later use.</p> 
-----------------------------------------------------------------------------------------------------------------------------------------------------------------------------------------------------------------------------------------------------------------	--------------------------------------------------------------------------------------------------------------------	---------------------------------------------------------------------------------------------------------------------------------------------