



# CARTS & STANDS LVM2X2U 40 - 60" VIDEO WALL CART

## FUSION® SERIES



### FEATURES

- CONTROLZONE™ LEVELING**  
Industry-first feature allows post-installation fine tuning of height and leveling, up to 0.75" (10 mm) of adjustment up or down.
- INDEPENDENT ADJUSTMENT**  
Displays can be easily aligned with independent plumb and lateral shift adjustment.
- SMOOTH POSITIONING**  
Large rolling casters allow for smooth positioning. One locking caster included on each leg to secure installation.
- HEAVY-DUTY CONSTRUCTION**  
Solid construction supports displays up to 60" and 125 lbs (56.7 kg).
- CABLE MANAGEMENT**  
Integrated cable management provides a clean installation.

### WHAT YOU NEED TO KNOW

#### ABOUT LVM2X2U

Can be combined with FCA2X1U accessory to support 2x3 video wall configurations.

#### OTHER PRODUCT OPTIONS



#### LVM3X2U

3 x 2 Micro-Adjustable Large Freestanding Video Wall



#### LVM3X3U

3 x 3 Micro-Adjustable Large Freestanding Video Wall

### SPECIFICATIONS

Dimensions* (HxWxD)	74.5 x 72 x 40.4" (189.2 x 182.9 x 102.6 cm)
Micro Height Adjustment	up to 0.75" (19 mm)
Plumb Adjust	up to 0.75" (19 mm)
Weight Capacity	125 lbs (56.7 kg) per screen**
Colors	Black

\* Dimensions do not include interface bracket

\*\* Listed weight capacity for LVM2X2U and LVM3X2U. Per screen weight capacity for LVM3X3U is 100 lbs (45.4 kg).

### RECOMMENDED ACCESSORIES



**FCA2X1U** 2x1 Video Wall Adapter

### TECHNICAL DRAWINGS

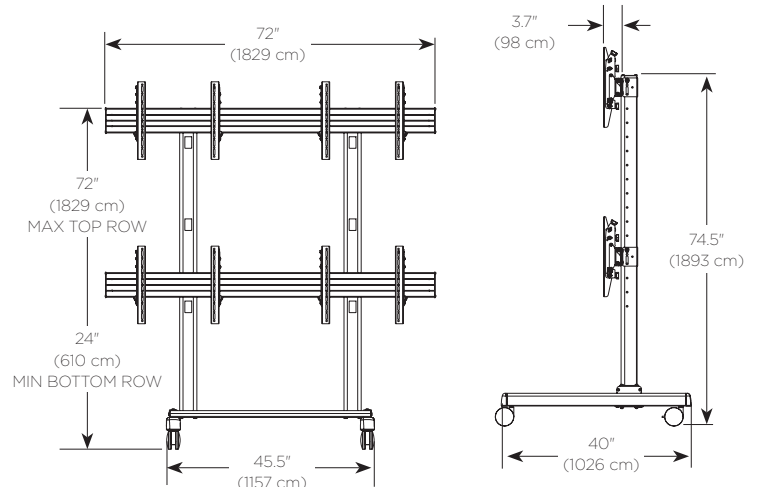

For a complete list of cart & stand accessories see pages **93 - 94**.