



FEATURES

- 1 CENTRIS® TECHNOLOGY**
PATENTED FEATURE
 Provides smooth fingertip tilt in all directions using the screen's center of gravity. Screen angle stays set until you decide to readjust.
- 2 EASY 3-STEP INSTALLATION**
 Ships fully assembled, clamp option can be installed from top of desk, grommet bolt through hardware included.
- 3 INDEPENDENT HEIGHT ADJUSTMENT**
 Dual arm, dual monitor. Maximize possible viewing angles. Adjust the height and position of each screen independently for ergonomic alignment.
- 4 ADVANCED DISPLAY MOUNTING**
 Teardrop hole pattern makes mounting the screen quick and easy.



SPECIFICATIONS

| | |
|-----------------------------|-------------------------|
| Depth from Wall | 2.19" (56 mm) |
| Max. Extension | 20" (508 mm) |
| Height Adjustment | 13.25" (337 mm) |
| Tilt | ±15° |
| Weight Capacity Per Monitor | 5-20 lbs (2.3 - 9.1 kg) |
| Grommet size | 0.38 - 3" (10 - 76 mm) |
| Colors | Black, Silver |

WHAT YOU NEED TO KNOW

INSTALLING THE MONITOR MOUNT

The mounting surface thickness must not exceed 3.2" (81 mm).

OTHER PRODUCT OPTIONS



KGL220
 Dual Arm Monitor/Laptop Desk Mount

TECHNICAL DRAWINGS

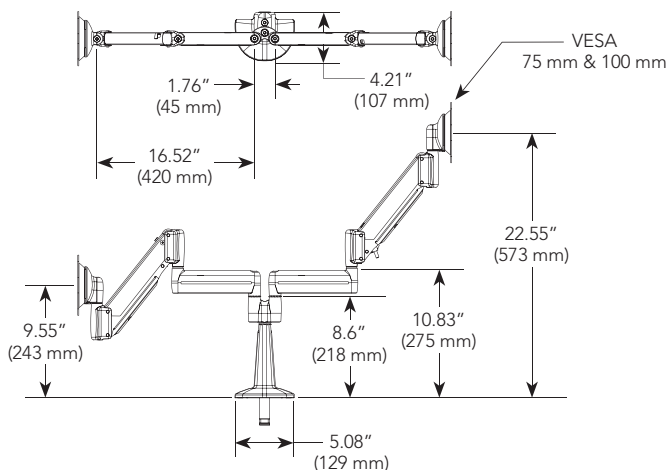

RECOMMENDED ACCESSORIES



KSA1007 ■ Centris Quick Release Interface



KSA1008 ■ Extended Desk Clamp Bracket
 – Compatible with 2.5" - 5" (64-127 mm) thick surfaces



KSA1012 ■ Extended Reach Desk Clamp Bracket

For a complete list of monitor mount accessories see page 111.