

# SYSTEMA

Systema | Monitor Spring Arm | Desk Mount

## Component Checklist

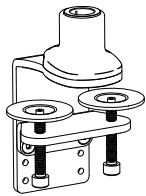

Desk Clamp

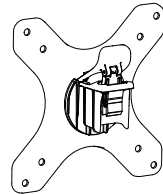

VESA monitor head

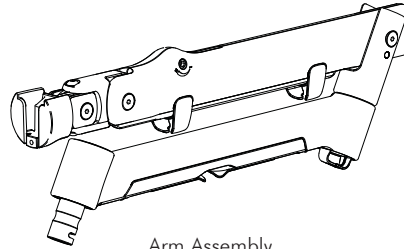

Arm Assembly

### HARDWARE

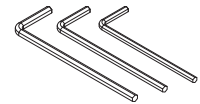

3/4/5mm Allen Keys

### Display Mounting Screws



M4 x 12/16/25mm (x4)  
Black Phillips Head Mounting Screws

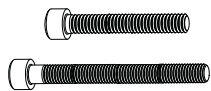

M8 x 54/80mm (x1)  
Bolt Through Screws

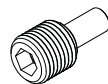

Rotation Lock  
Set Screw



M4 x 14mm (x1)  
Silver Phillips Head  
Security Screw



Bolt Through  
Washers (x3)



Display Mounting  
Spacers (x4)

### Tools Required:

- Power Drill
- Phillips Head Screw Driver
- 9mm (0.35") Drill Bit

## IMPORTANT INFORMATION:

- ! **IMPORTANT - Install Systema Monitor Spring Arm as per installation instruction.**
- ! This product supports a minimum load of 1.5kg (3.3lbs) and maximum load of 8kg (17.6lbs).
- ! The manufacturer accepts no responsibility for incorrect installation.

## Step 1. Check Components

Check what you have received against the component checklist and hardware above.

## Step 2. Mount Base

### Option 1: Mount using Desk Clamp

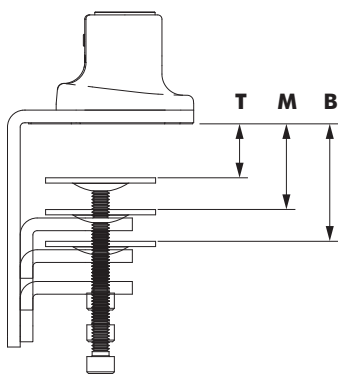

**1.1** The Desk Clamp bracket can be repositioned to suit different mounting surface thicknesses. The maximum mounting surface thicknesses supported are listed below from the Top to Middle to Bottom Screw Holes.

|               |                    |
|---------------|--------------------|
| <b>Top</b>    | 0 - 38mm (default) |
| <b>Middle</b> | 11 - 53mm          |
| <b>Bottom</b> | 25 - 68mm          |

If you need to reposition the desk clamp bracket or you have no access to the rear of your table continue to **Step 1.2**.  
If you **DO NOT** need to reposition the desk clamp bracket and you have access to the rear of your table skip to **Step 1.5**.

**1.2** Remove the M6 x 12mm Socket Head Countersunk Screws to release the Desk Clamp Bracket.

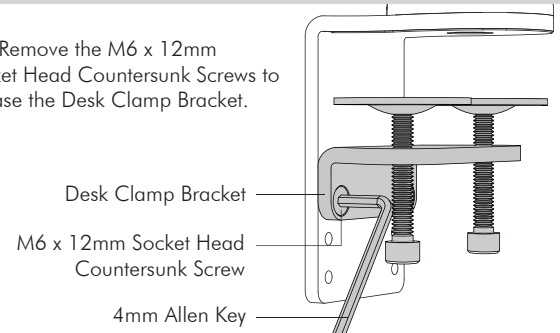

**1.3** Place in desired location.

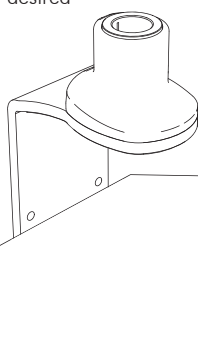

**1.4** Reattach Desk Clamp Bracket.

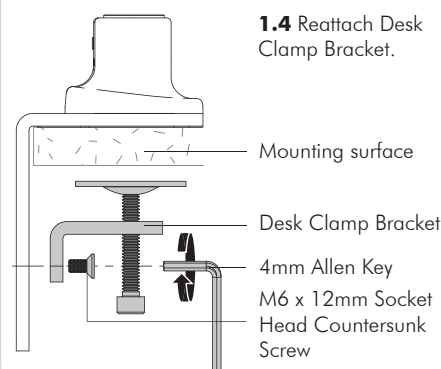

**1.5** After positioning your Desk Clamp, screw Pressure Plates in and **Tighten Firmly**.

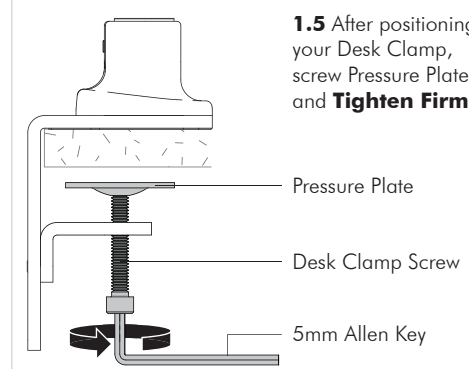

## Step 2. Mount Base (cont.)

### Option 2: Bolt Through

**1.1** Remove M8 Countersunk Socket Head Screw to release the Spigot Housing from the Desk Clamp.

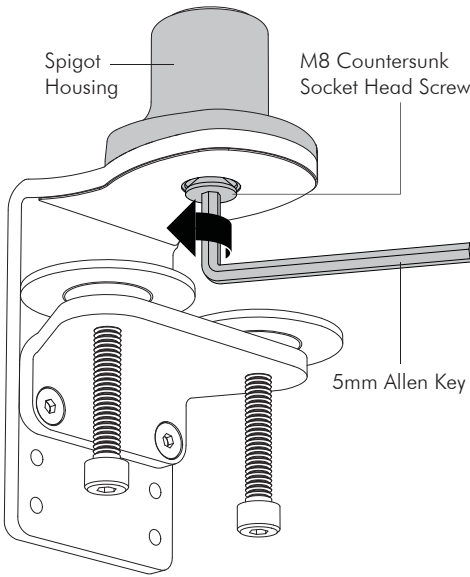

**1.2** Drill a 9mm (0.35") hole in the Mounting surface in the desired position and assemble as shown below. (Refer to page 5 for the "Ergonomic Guidelines.")

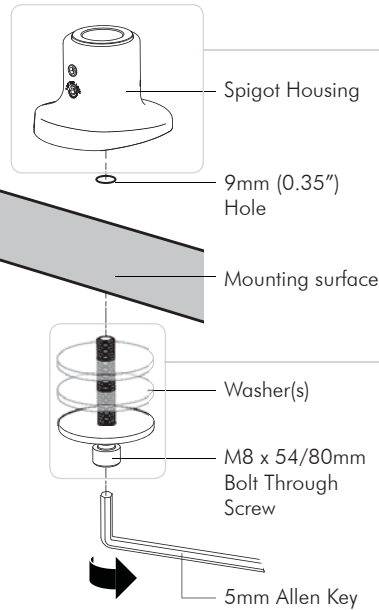

It is recommended that the Spigot Housing be mounted towards the rear edge of the work surface. The Logo must face the **front**.

By using either the 54mm or 80mm Bolt Through Screw with 1 - 3 washers, mounting thicknesses from 10mm to 63.5mm are supported.

| Mounting Thickness | Washers Needed | Bolt Through Screw |
|--------------------|----------------|--------------------|
| 10 - 13mm          | 3              | 54mm               |
| 13 - 16mm          | 2              |                    |
| 16 - 36mm          | 1              |                    |
| 36 - 39mm          | 3              | 80mm               |
| 39 - 42mm          | 2              |                    |
| 42 - 63.5mm        | 1              |                    |

## Step 3. Mount Arm Assembly

**3.1** Push Arm Assembly firmly down into the Spigot Housing.

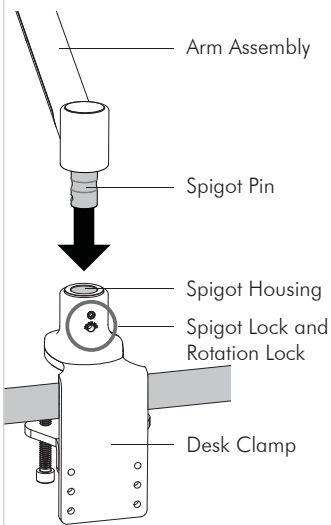

**3.2** Ensure Arm Assembly is facing away from the Spigot Lock and Rotation Lock.

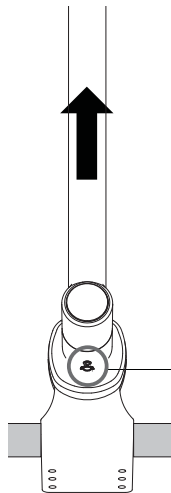

**3.3** Fasten the Spigot Lock set screw in with the **3mm Allen Key**. Turn the Allen key until initial resistance is felt. You may fine tune the rotation resistance up to a maximum of a **1/4 turn**.

**Do not overtighten.**

**Note:** The initial point of resistance may occur at any point on the turning circle of the Allen Key.

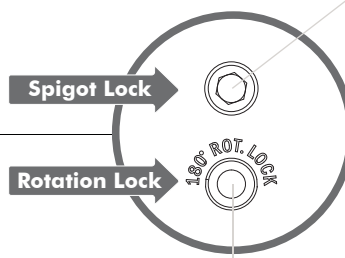

**Tighten**

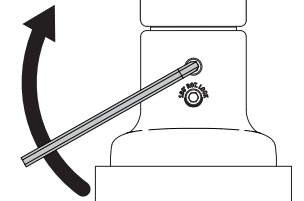

Until initial point of resistance

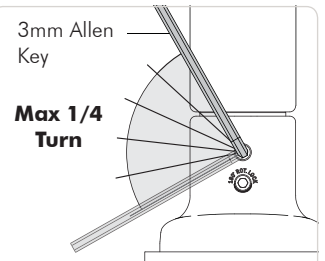

Fine tune the rotation resistance

**3.4 OPTIONAL** Insert Rotation Lock set screw. This will limit the Arm Assembly's travel to 180°.

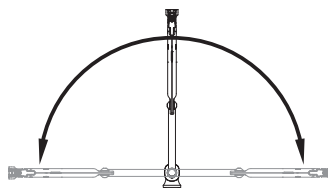
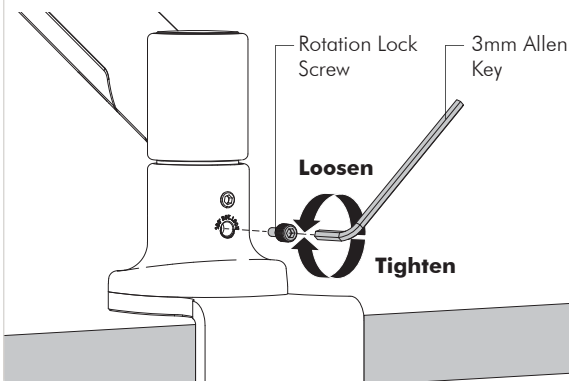

**With Rotation Lock**

**Max 180° Turn**

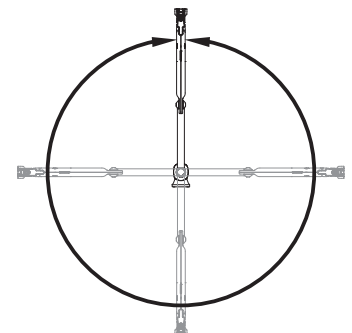

**Without Rotation Lock**

## Step 4. Install VESA monitor head

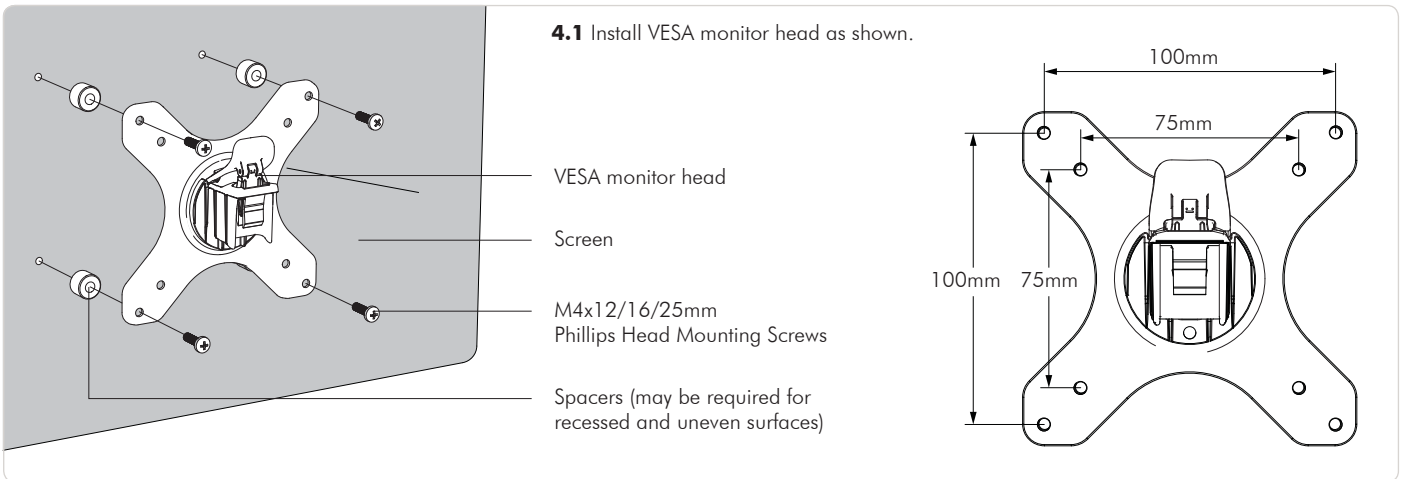

## Step 5. Mount Display

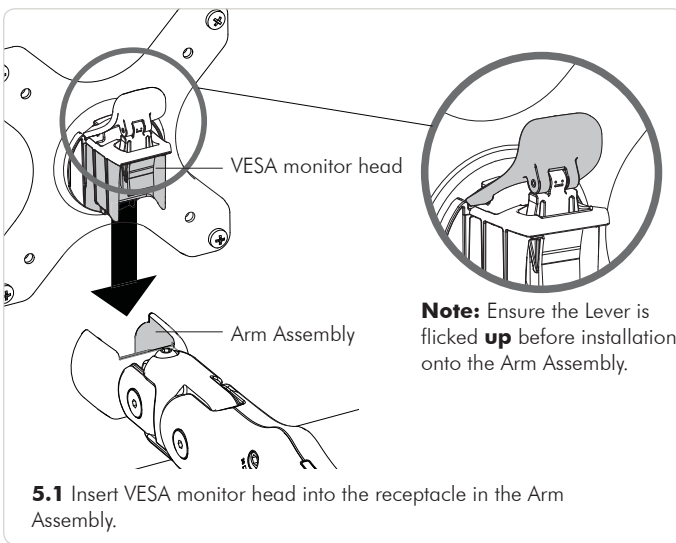

**Note:** Ensure the Lever is flicked **up** before installation onto the Arm Assembly.

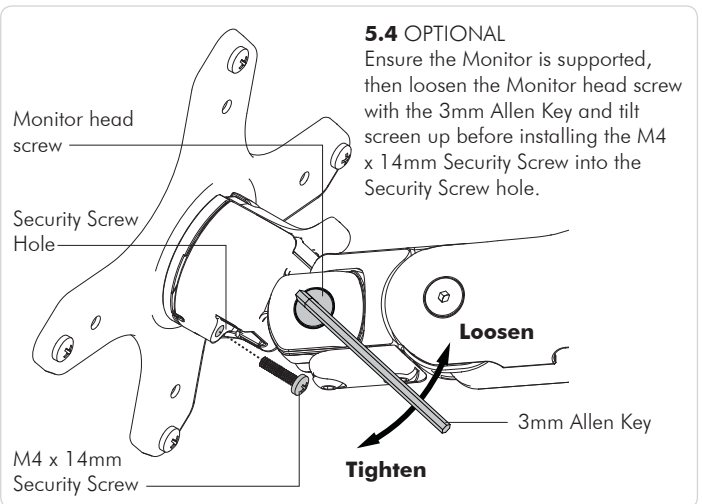
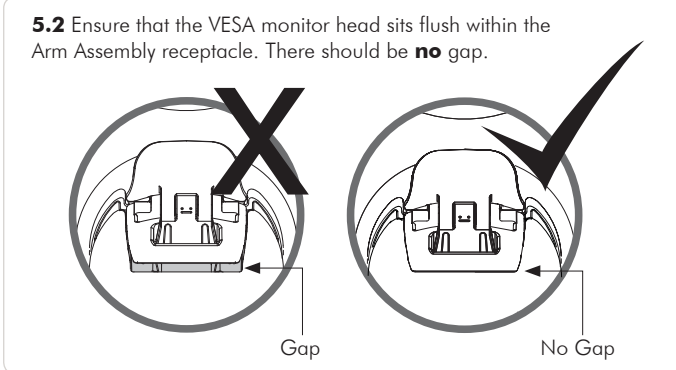
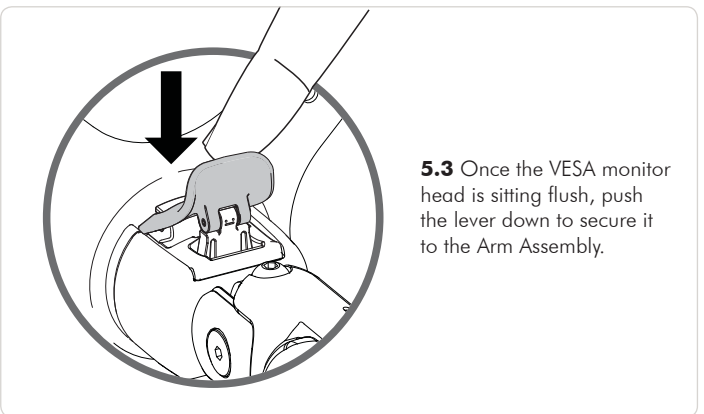

## Step 6. Adjust Spring Tension

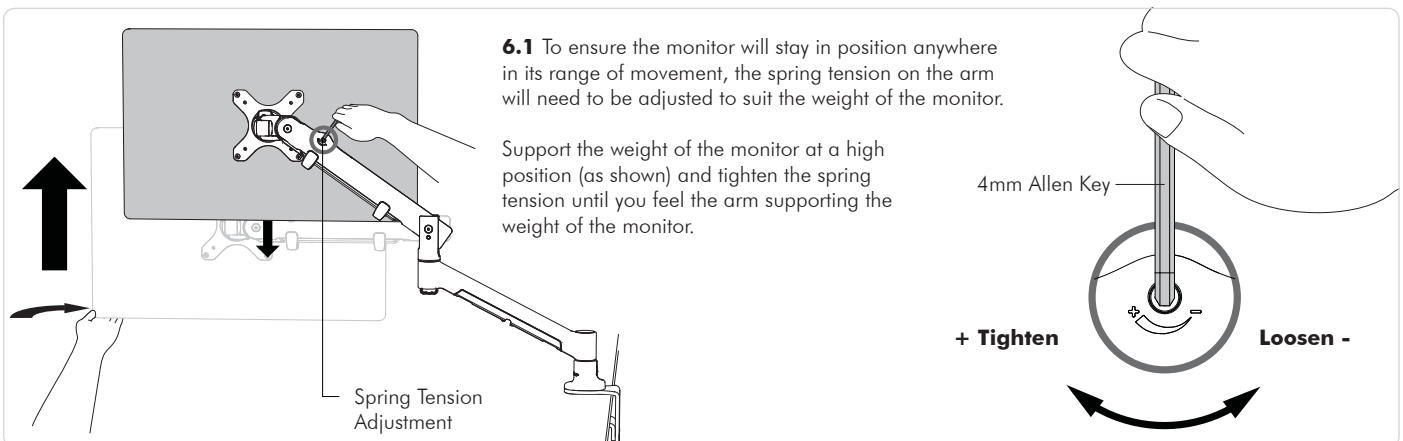

## Step 6. Adjust Spring Tension (cont.)

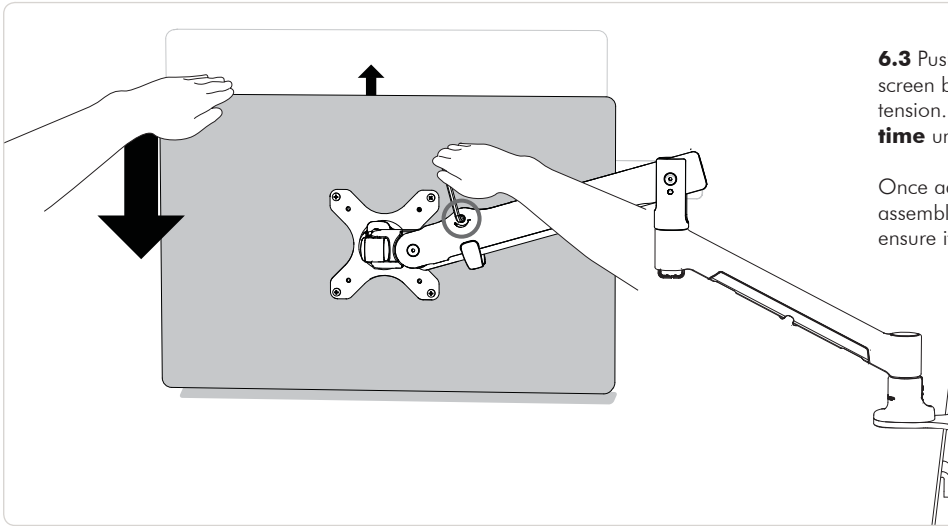

**6.3** Push the monitor down to the bottom. If the screen bounces back this may indicate too much tension. Loosen the spring tension **1 turn at a time** until no bounce is observed.

Once adjustments have been made, move the arm assembly through the full range of movement to ensure it moves freely and holds its position.

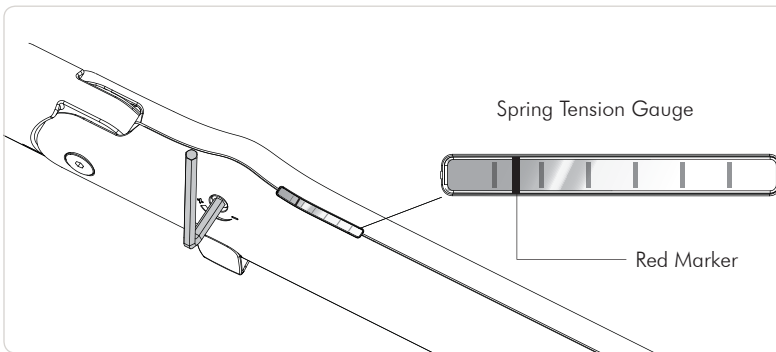

### 6.4 MULTIPLE ARM INSTALLATIONS

When installing multiple SYSTEMA products using monitors of the same weight, observe the location of the **red marker** on the Spring Tension Gauge and set the tension to the same position on all arms.

**Max weight: 8 kg.**

## Step 7. Cable Management

**7.1** Plug your cables into the monitor and follow this cable management system route.

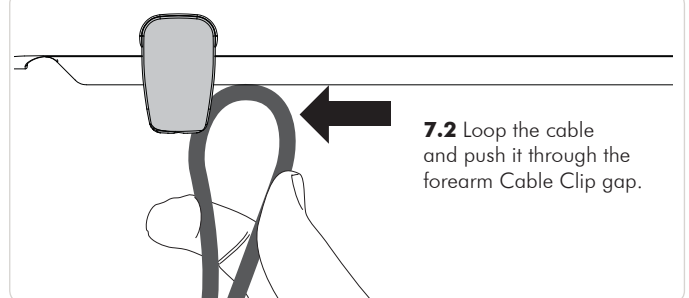
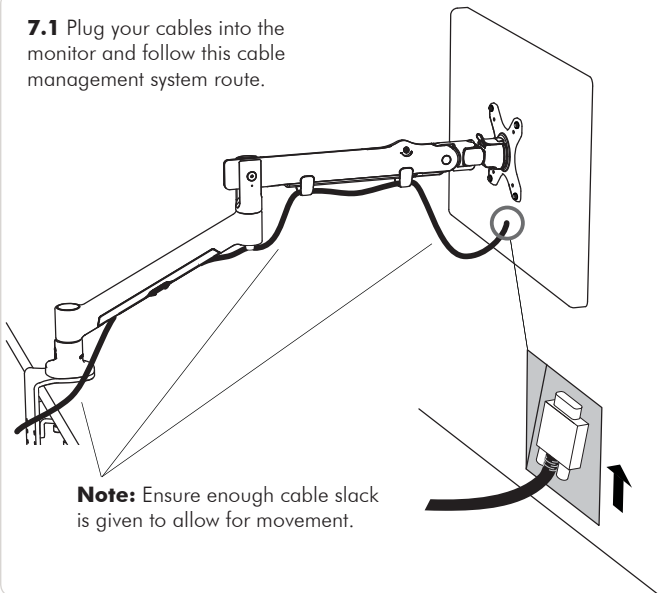

**7.2** Loop the cable and push it through the forearm Cable Clip gap.

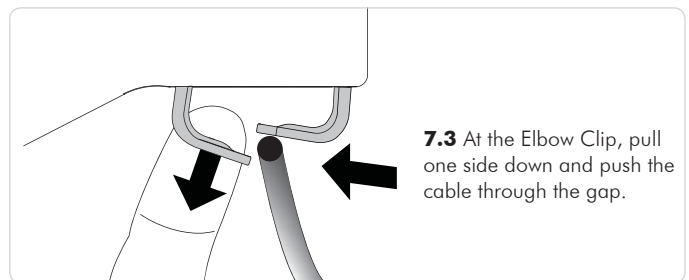

**7.3** At the Elbow Clip, pull one side down and push the cable through the gap.

**7.4** Push the cable up into the gap in the lower arm Cable Cover.

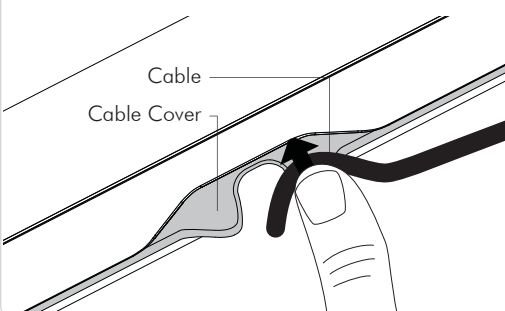

**7.5** Whilst maintaining pressure on the cable, slide the cable into the groove and follow it up.

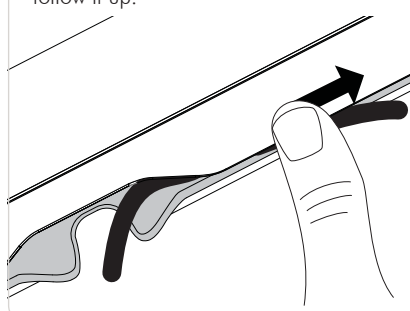

**7.6** Whilst maintaining pressure on the cable, slide the cable into the groove and follow it down.

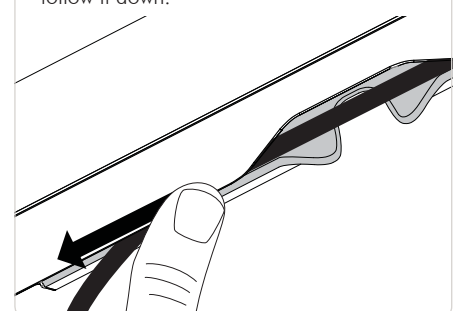

## Step 8. Adjusting the Display Bracket

### Portrait/Landscape

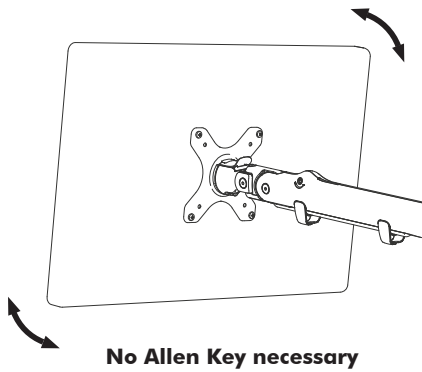

### Tilt (Screen angle up/down)

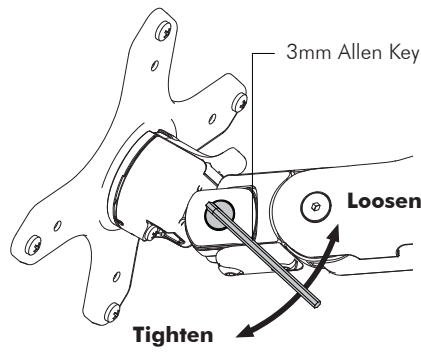

### Pan (Screen angle left/right)

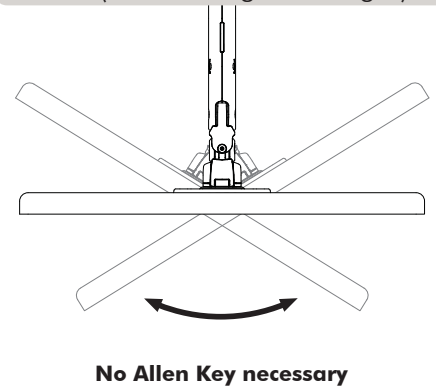

## Ergonomic Guidelines

**Many experts believe that the extended use of any computer screen has the potential to cause serious injury to your eyes, neck and back. This can be largely avoided by correctly positioning your display.**

**Viewing angle:** Ergonomists recommend that the optimal position of your display should be slightly below eye level. When looking at the display's centre the user should have a downward visual angle of approximately 10°-20°.

**Height:** As a guide, the height (**h**) of your display should approximately be as follows:

- Tall Male (Max): 560mm (22")
- Short Male (Min): 368mm (14.5")
- Tall Female (Max): 520mm (20.5")
- Short Female (Min) 356mm (14")

**Distance:** For visual comfort, a viewing distance (**d**) between 500mm (20") to 750mm (29.5") is recommended.

**Tilt Angle:** Angular adjustments to reduce reflection on your monitor should range between 5° forward tilt to 15° backward tilt.

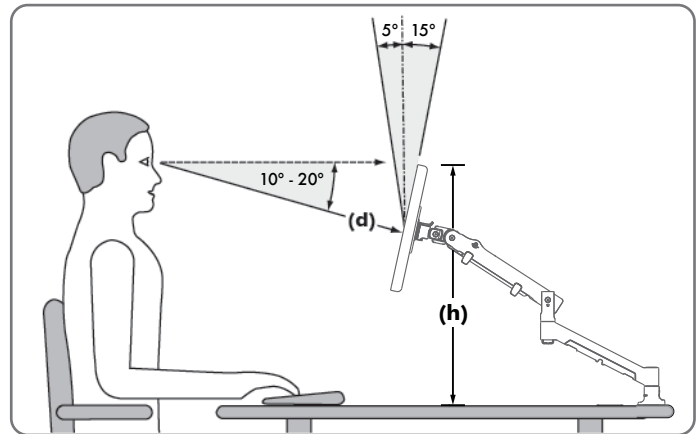

## Installation Complete



No portion of this document or any artwork contained herein should be reproduced in any way without the express written consent of Atdec Pty Ltd. Due to continuing product development, the manufacturer reserves the right to alter specifications without notice. Published 19.02.14 ©