

ITEM NO.	QTY.	PART NUMBER	DESCRIPTION
1	1	B030T100	TABLET TRAY FACE
2	1	B030T105	TABLET TRAY BOX
3	1	B030T110	TABLET TRAY SLIDER
4	1	B030T113	TABLET TRAY SLIDER HOOK FOR 8" & 12" TABLETS
5	1	B030T116	TABLET TRAY RIGHT HOOK FOR 12" TABLETS
6	1	B030T121	TABLET TRAY RIGHT HOOK FOR 12" TABLETS
7	1	M030D700	TABLET TRAY SLIDER NUT
8	6	B030H101	TABLET TRAY NYLON FLANGED BUSHING
9	3	B030C502	TABLET TRAY CLAMP CUSHION
10	1	B030H104	CENTURY SPRING #80448, .359 OD X 1.25 L X .031 MUSIC WIRE, BARE
11	2	B115C238	KUS TRAY STOP CAP
12	3	B000H170	1/2 X 1" X.040 ACRYLIC DBL SIDE TAPE
13	9	H6-32JAMNYLOCKZ	6-32 JAM NYLOCK NUT ZINC
14	9	H6-32X.375FPHMSSS	6-32 x 3/8 FLAT PHILLIPS 100 DEG HEAD MACHINE SCREW S/S
15	2	H6/32X1/4FPHMSSS	6/32 x 1/4 FLAT PHILLIPS HEAD MACHINE SCREW S/S
16	1	H.25-20X.5FMK	SMALL CMT KNOB
17	2	M021H105	.485"DIAx .485" BUSHING
18	1	B115H252	HANDLE (COMPOSITE KB)
19	2	H10-24X.375PPHMSSS	10-24 X 3/8" PAN PHILLIPS HEAD MACHINE SCREW S/S
20	4	H0.7X12M4PMSZ	0.7 x 12 M4 PHILLIPS MACHINE SCREW ZINC
21	1	SNKIT	TABLET TRAY SECURITY NUT & KEY KIT
22	1	H.25PVCWASH	WASHER, PVC, 1/4X3/4X1/16"

REVISIONS				
ECN#	REV.	DESCRIPTION	DATE	APPROVED
4340	-	NEW ASSEMBLY	11/21/17	RR

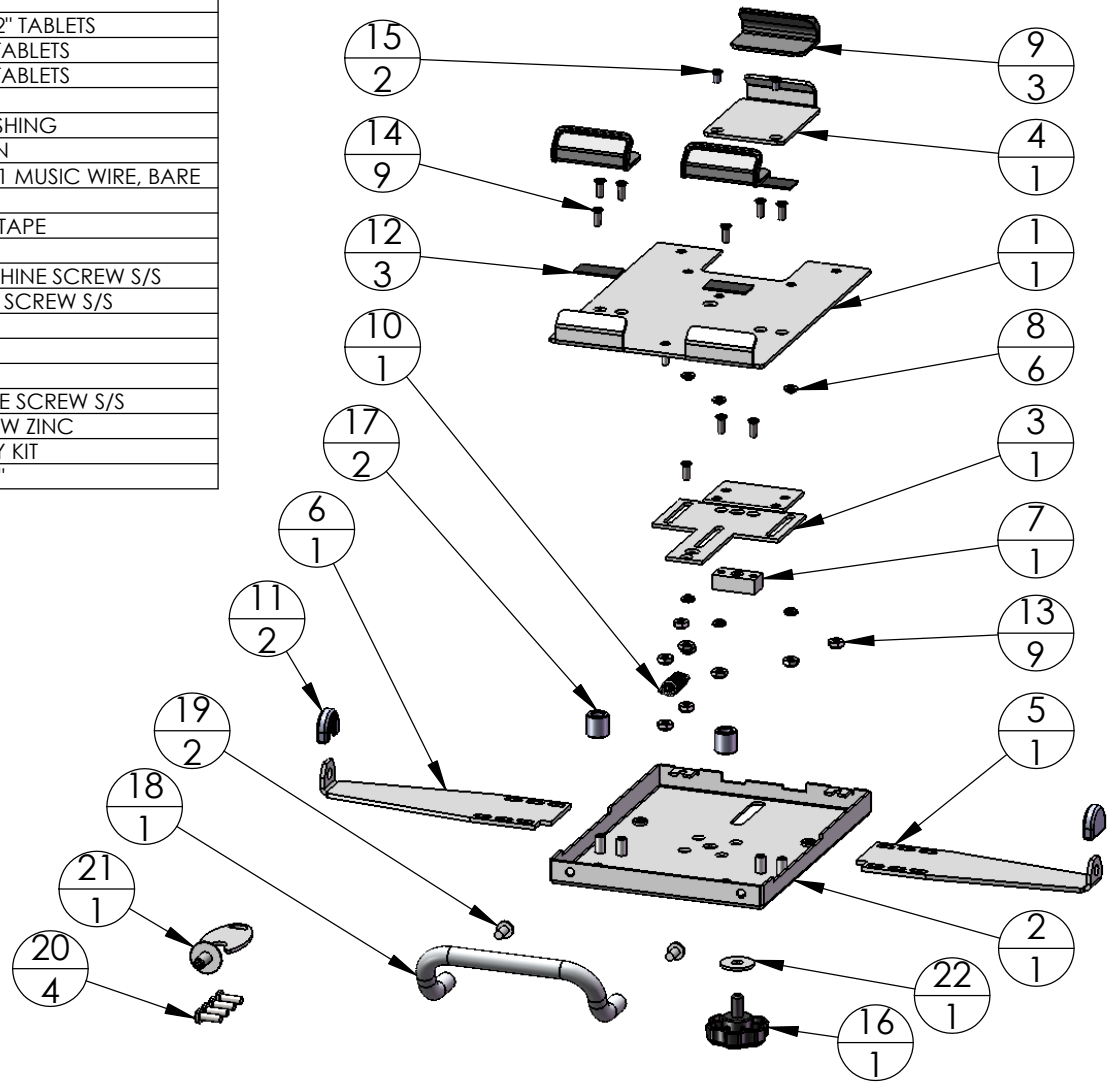
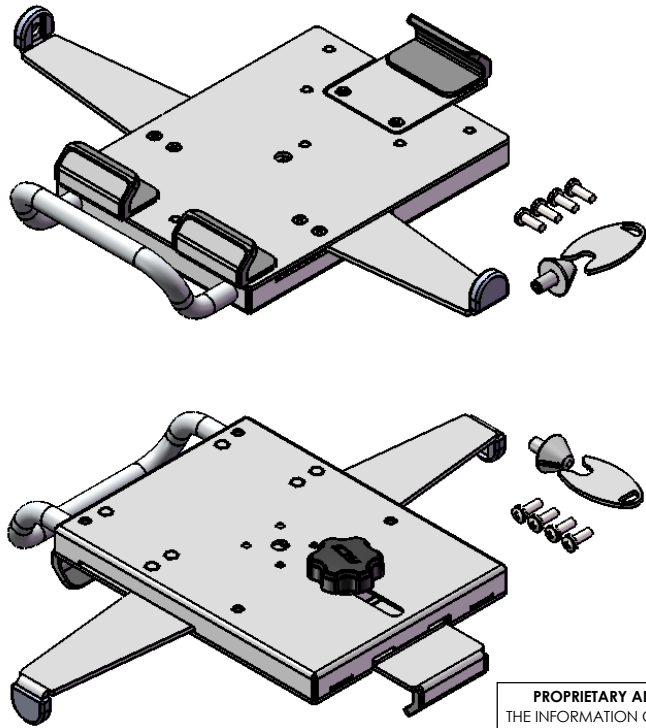

PROPRIETARY AND CONFIDENTIAL
 THE INFORMATION CONTAINED IN THIS DRAWING IS THE SOLE PROPERTY OF ICW USA,Com,Inc ANY REPRODUCTION IN PART OR AS A WHOLE WITHOUT THE WRITTEN PERMISSION OF ICW USA,Com,Inc IS PROHIBITED.

		DIMENSIONS ARE IN INCHES		NAME		DATE		ICW USA.Com, Inc	
		TOLERANCES: FRACTIONAL ± ANGULAR: MACH ± BEND ± TWO PLACE DECIMAL ± THREE PLACE DECIMAL ±		DRAWN RR		11/21/17		1487 Kingsley Dr. Medford, OR 97504 (541) 608-2824 Fax (541) 608-2797	
		MATERIAL		CHECKED				DESCRIPTION:	
		FINISH		ENG APPR.				TABLET TRAY 12" VESA MOUNT	
NEXT ASSY		USED ON		MFG APPR.				SIZE DWG. NO.	
APPLICATION		DO NOT SCALE DRAWING		Q.A.				A TABV12	
				COMMENTS:		TABLET SIZE RANGE: HEIGHT 7.5"-9.0" WIDTH 11.5"-13.5" THICKNESS UP TO .6"		SCALE: 1:4 WEIGHT: SHEET 1 OF 1	
				REV. -					